

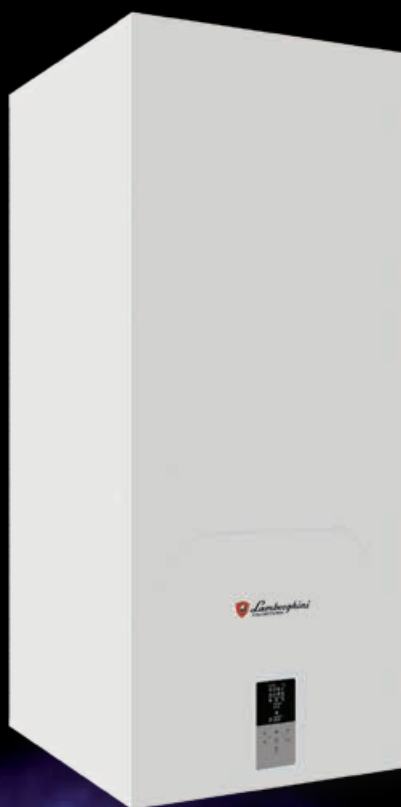

Lamborghini
CALORECLIMA



Idola SW-T 3.2
Air-water heat pump for heating
and domestic hot water production

IDOLA SW-T 3.2

THE IDEA



IDOLA SW-T 3.2 is a heat pump, for heating and the production of domestic hot water, designed for applications in small and medium-sized housing units. Each of its components has been designed with the renovation of existing heating systems in mind for the replacement of boilers and electric water heaters, ensuring the same comfort, with an economical and environmentally friendly solution.

It is a 360° smart solution for domestic well-being, which uses clean energy sources such as electricity, air and solar photovoltaic, as an alternative to the use of traditional fossil fuels.

Efficiency, ecology and flexibility are the characteristics that distinguish IDOLA SW-T 3.2 and differentiate it from a conventional heat generator.

IDOLA SW-T 3.2 RANGE	Heat output in heating (A7W35)	Max temperature water produced DHW	SCOOP (water produced 35°C)	ErP class in heating	SEER (water produced 7°C)	Tank capacity DHW	Energy efficiency class DHW	Loading profile DHW
	kW	°C	kW/kW		kW/kW	liters		
model 4	4.2	70*/65	4.85	A <small>A+ D</small>	4.99	100	A <small>A+ F</small>	M
model 6	6.3	70*/65	4.95	A <small>A+ D</small>	5.34	100	A <small>A+ F</small>	M
model 8	8.4	70*/65	5.21	A <small>A+ D</small>	5.83	100	A <small>A+ F</small>	M
model 10	10	70*/65	5.19	A <small>A+ D</small>	5.98	100	A <small>A+ F</small>	M

* With auxiliary electric booster

THE IDOLA S 3.2 FAMILY

SW-T 3.2 THE LATEST ADDITION

IDOLA SW-T 3.2 is the latest addition to the Lamborghini CaloreClima family of IDOLA S 3.2 Full Inverter split heat pumps.

"**Split**" means that the cooling circuit is divided between the outdoor unit and the indoor unit.

The outdoor unit contains the heart of the cooling circuit, from the compressor to the fan with the air side exchanger and is connected with the refrigerant gas pipes to the indoor unit.

Thanks to its wide operating range (among the widest on the market), IDOLA SW-T 3.2 works at outside temperatures to -25°C and produces hot water up to 65°C in nominal conditions.

The new Full Inverter concept by Lamborghini CaloreClima uses DC inverter modulations on the 3 main energy-intensive components of the machine, i.e. compressor, fan and pump. This makes it possible to modulate the power supplied by precisely tracking the thermal load and offering the user very high efficiencies and significant energy saving.

The indoor unit, on the other hand, contains the heart of the generator's hydraulic circuit, with all the main pre-installed components, the 100-liter DHW storage tank, the high-efficiency circulating pump, the three-way valve, expansion vessels and the 15-liter inertial storage tank.

IDOLA SW-T 3.2 is equipped with a refined electronic control, designed for the integrated management of domestic hot water production and two heating zones at different temperatures.



COMPONENTS

INTERNAL TECHNOLOGY

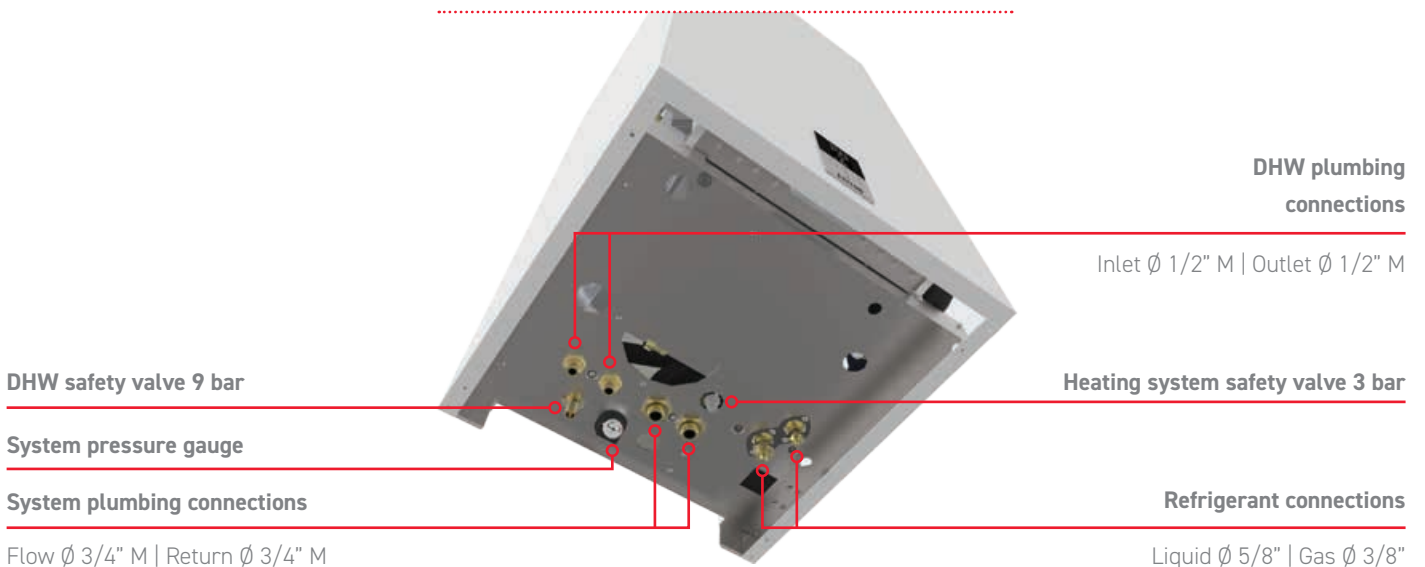
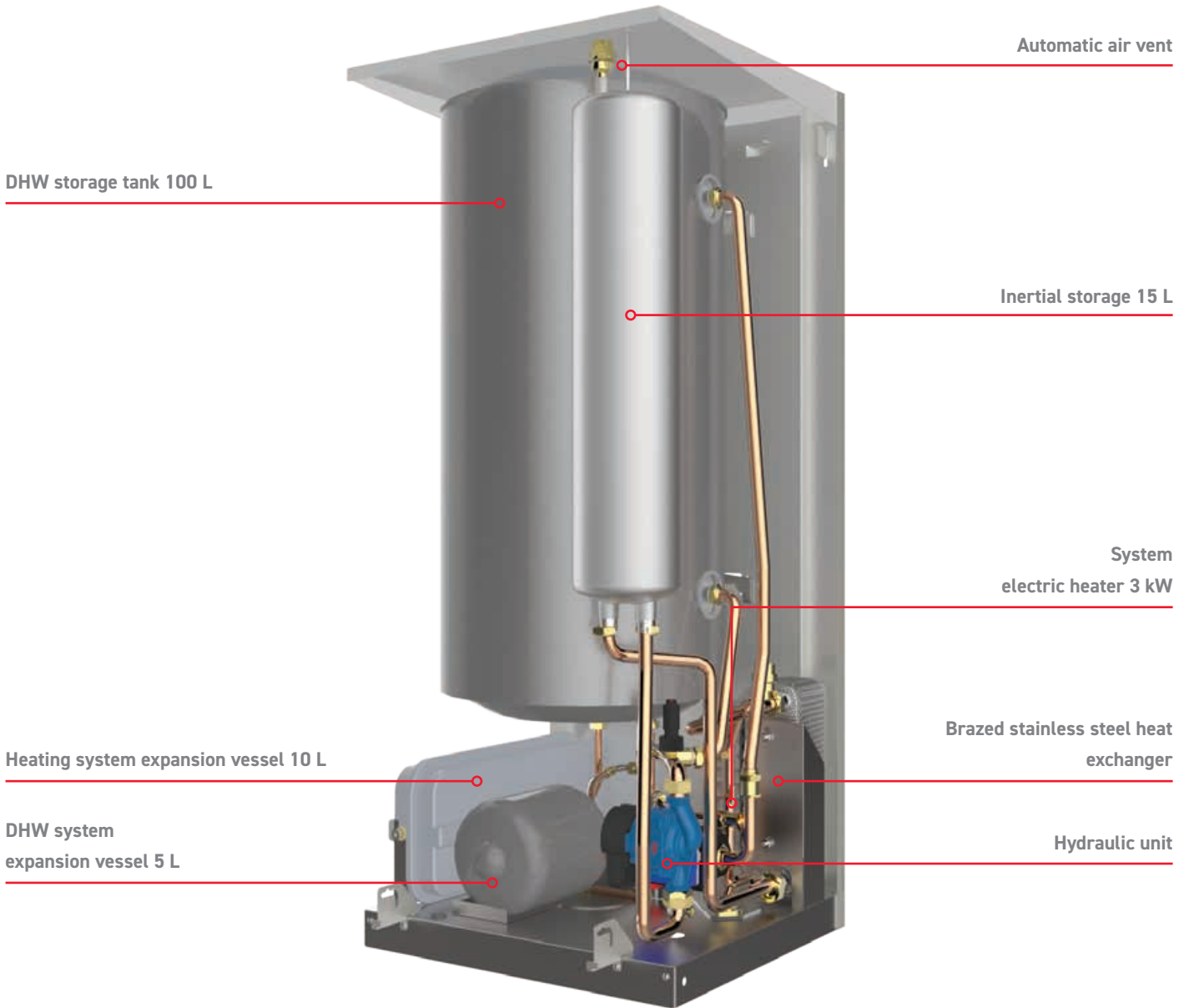

COMPONENTS

INTERNAL TECHNOLOGY

BLUE SILICON anti-corrosion storage tank and coil

The DHW tank and the heat exchange coil are treated with a special enamel enriched with titanium called **BLUE SILICON**. This special protection ensures a lasting barrier against corrosion and the galvanic deterioration process. A magnesium anode is installed on each unit for further protection against stray currents.

BLUE FOREVER anti-limescale heating element

The IDOLA SW-T 3.2 DHW storage tank has a 1.2 kW **BLUE FOREVER** heating element to reduce waiting times for tank reinstatement. The booster function can be activated from the control panel.

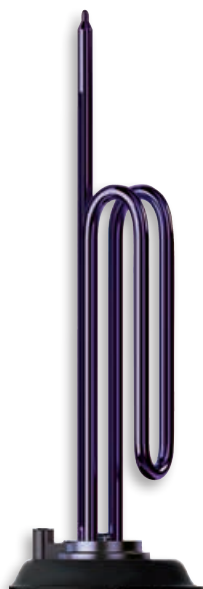
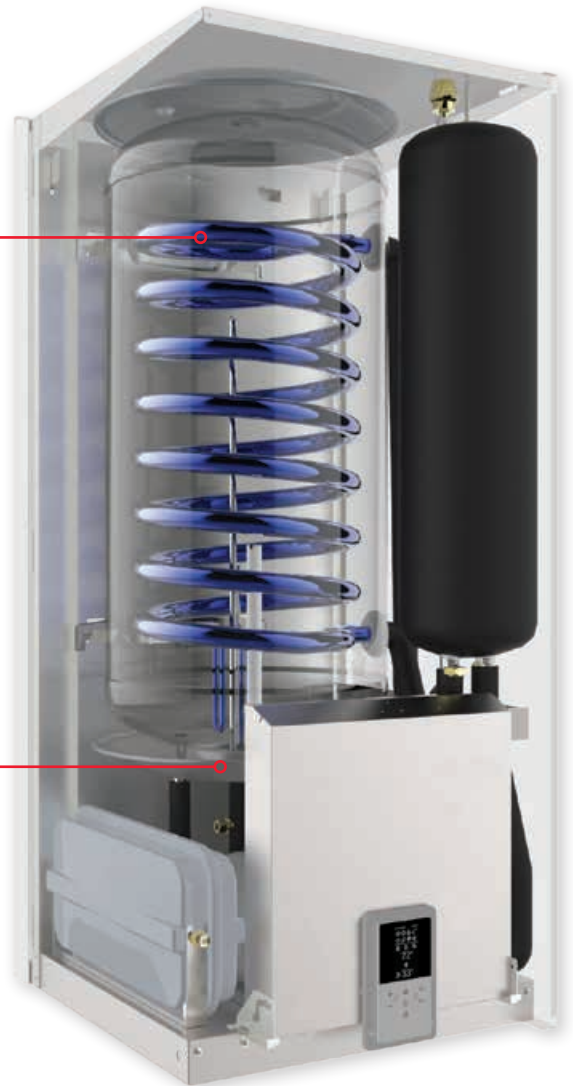

patented

BLUE FOREVER new generation ultra-performing heating elements are installed on Lamborghini CaloreClima heat pumps with integrated domestic hot water storage. A special surface treatment almost completely stops scale from forming on the heating element, thereby ensuring longer life and high thermal efficiency.

TEST WITH UNTREATED HEATING ELEMENT

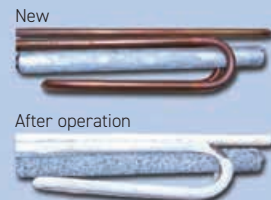

TEST WITH "BLUE FOREVER" HEATING ELEMENT



Limescale deposit practically non-existent

COMPONENTS

SIMPLE AND "CLEAN" INSTALLATIONS



Spacer frame (80 mm) for boiler replacements

IDOLA SW-T 3.2 is a generator carefully designed to facilitate the replacement of old boilers, without the need to restructure the heating system and domestic hot water system. To this end, an accessory for boiler replacement has been studied without necessarily having to break the supporting wall to redo the plumbing connections of the heating and DHW systems.

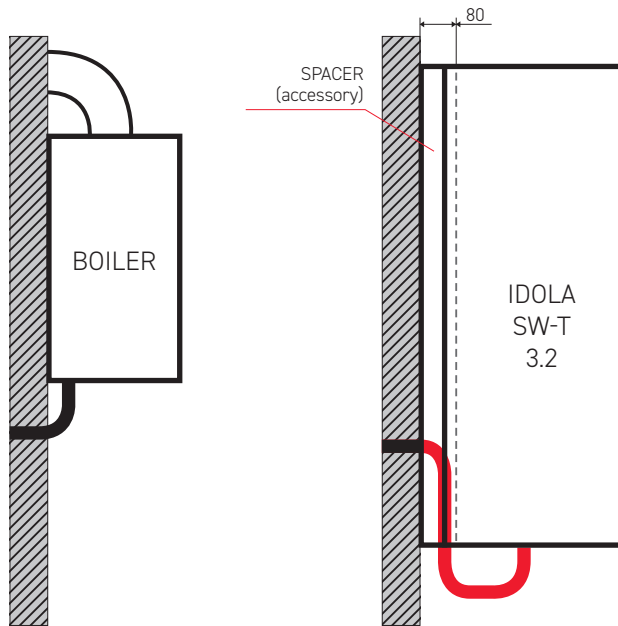

The kit consists of a spacer frame to be installed between the heat pump and the wall, so as to create an 80 mm space, sufficient for the water and gas connection pipes.



To avoid heat loss and the formation of condensate, each component of the indoor unit has been insulated with highly insulating material so as to minimize inefficiencies due to dispersion and dripping during operation in cool mode



IDOLA SW-T 3.2 is designed so that all the components of the internal machine can be reached from the front by rotating forward the box containing the electronic board and the display

THE CONTROL SYSTEM





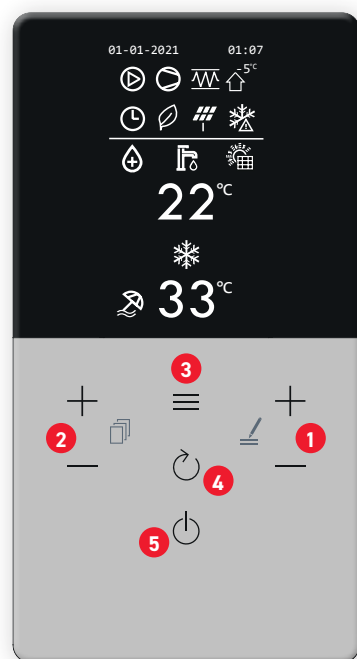







USER INTERFACE / LEGEND OF DISPLAY ICONS

The user interface uses **Capsense buttons** and a **2.8" graphic display**, which allow dialogue with the product in an intuitive and extremely simple way. The IDOLA SW-T 3.2 electronic system offers a wide range of functions to allow the user to customize operation of the heat pump according to needs and habits.



- 1**
DHW and system temperature adjustment
- 2**
Menu selections
- 3**
General menu / Confirm modified value
- 4**
Back to previous screen
- 5**
On / Off

- > **MODBUS PROTOCOL** It can be interfaced with BMS/BACS automation and management systems
- > **HEATING AND COOLING Full Inverter** modulation accurately tracks the desired setpoints, with the possibility of setting heating and cooling climate curves, further optimizing consumption for the user
- > **DOMESTIC HOT WATER PRODUCTION (DHW)** When the DHW temperature probe calls the machine, it automatically switches to the hot water storage tank with dedicated DHW setpoint.
- > **DHW STORAGE TANK HEATING ELEMENT** The DHW electrical integration serves as a booster, anti-legionella or reserve source in case of a fault
- > **FAST DHW** Priority to DHW production to bring the storage tank to the setpoint as quickly as possible
- > **ANTI-LEGIONELLA FUNCTION** Allows weekly anti-legionella cycles to be set
- > **PHOTOVOLTAIC AND GRID SMART GRID INPUTS** Digital **Smart Grid** inputs for managing an input from a photovoltaic system and the electricity grid. These allow optimizing consumption and bill costs
- > **SILENT MODE** It reduces the frequency of the compressor and the fan speed, so as to significantly reduce noise. Programmable according to time bands
- > **ON/OFF** from external contact. Activation and deactivation via an external contact (e.g. from a zone thermostat)
- > **HEAT/COOL** from external contacts. Summer/winter switching signal from outside (e.g. from the zone thermostat)
- > **ECO FUNCTION** Dedicated setpoint for "Eco" operation. Settable with daily time band
- > **FROST PROTECTION** Heat pump working in heating mode with circulating pump ON and possible activation of the electric booster

	HP circulating pump ON		ECO function active		Cooling mode active
	HP compressor ON		Photovoltaic integration ON		Heating mode active
	System supplementary heating element		Frost protection active		Vacation mode active
	Outside temperature		Anti-legionella function active	Z1	System first zone
	Timer		DHW production enabled	Z2	System second zone

SMART SYSTEMS

CONNECT CRP AND CONNECT CRP ZONE

The on-board machine interface communicates easily with the new **Connect CRP** smart systems, which can manage up to 8 thermostats (7 Connect CRP Zone + 1 Connect CRP which in turn has all the chronothermostat functions) divided into 2 zones, **one direct and one mixed**.



Connect CRP is the very latest remote controller accessible via **APP**, available for **iOS** and **Android**.

Connect CRP Zone, on the other hand, is a zone thermostat that communicates via **RF** with the Connect CRP.

It can be placed in a classic 502 box, or left stand-alone on its handy table-top feet.

EXAMPLE SYSTEM DIAGRAM

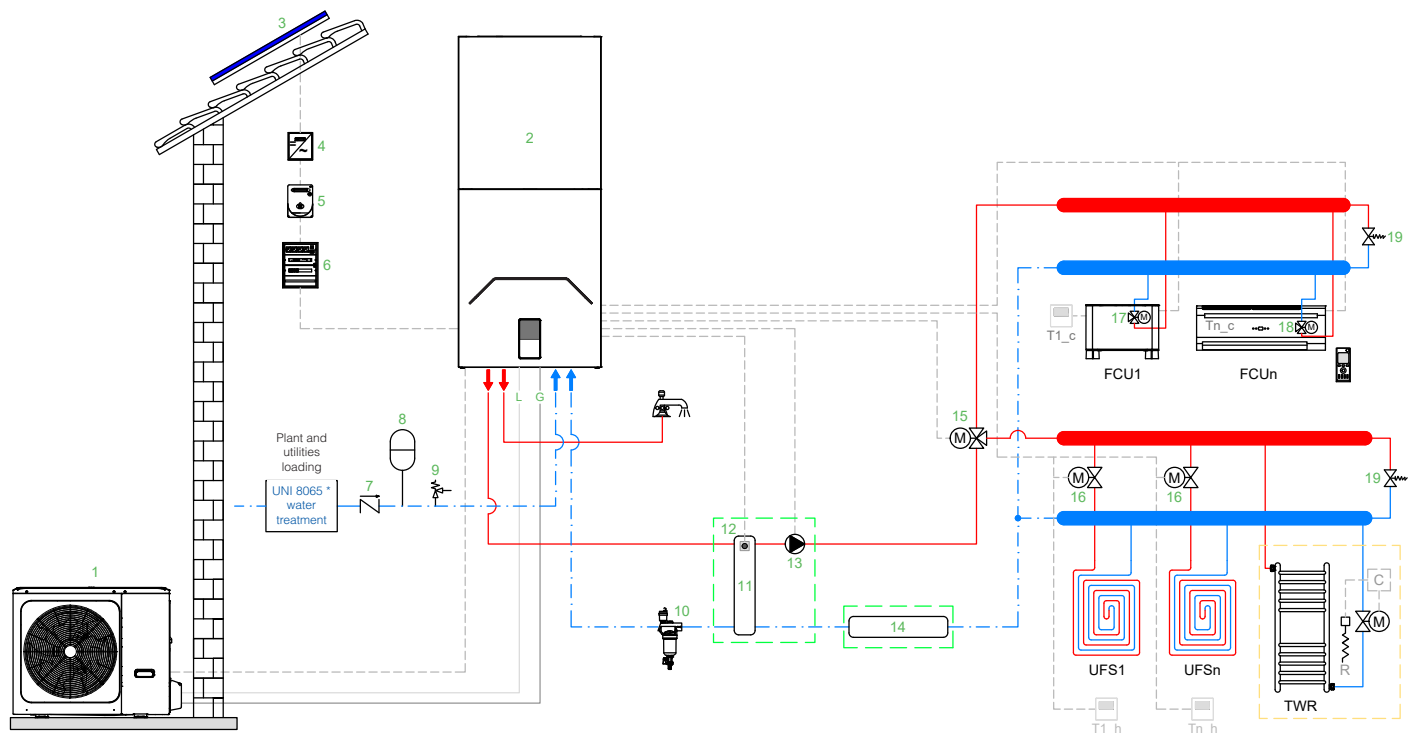

LEGEND 1 Outdoor unit 2 Indoor unit 3 Photovoltaic panel 4 Inverter 5 Meter 6 Electric panel 7 Non-return valve 8 DHW expansion vessel 9 DHW safety valve 10 Dirt separator 11 Inertial storage, hydraulic separation 12 Inertial storage upper probe Tbt1 13 P_o circulating pump 14 Inertial storage (series storage alternative) 15 Three-way diverter valve SV2 16 Motorized zone valve 17 Three-way valve (accessory, to be installed inside the fan coil) 18 Integrated three-way valve 19 Bypass valve 20 Water treatment UNI 8065 T1...n_c Room thermostat RT1 cool request T1...n_h Room thermostat RT1 heat request FCU1...n Cooling only air terminal UFS1...n Radiant floor heating only in n zones TWR Towel warmer for bathroom integration: if connected to the heating system, it must be integrated with a heating element (R) activated by the command (C) which simultaneously closes the valve (M); if not connected to the system, the heating is provided only by the heating element (R) activated via the command (C) G Gas Line L Liquid Line *OPTIONAL* See Water treatment diagram according to UNI 8065

TECHNICAL DATA

SUMMARY TABLES

OUTDOOR UNIT TECHNICAL DATA		4	6	8	10	
Electrical power supply	Vac / Hz	220-240 / 50				
Compressor type		twin rotary DC				
Compressors / Cooling circuits	no.	1 / 1				
Type of exchanger		finned coil				
Type of fans		axial DC				
Fans	no.	1				
Liquid line cooling connections ***		1/4" SAE / Ø 6.35		3/8" SAE / Ø 9.52		
Gas line cooling connections		5/8" SAE / Ø 15.88				
Type of refrigerant		R32				
GWP	t-CO ₂ eq	675				
Factory refrigerant charge *	Kg / t-CO ₂ eq	1.5 / 1.01		1.65 / 1.11		
Cooling lines (max length / max vert. difference)	m	30 / 20				
SWL - Sound power level in heating **	A7W35	dB(A)	56	58	59	60
	Max	dB(A)	60	61	61	62
	Sil. 1	dB(A)	56	56	57	58
	Sil. 2	dB(A)	53	53	55	55
SWL - Sound power level in cooling **	A35W18	dB(A)	56	58	60	60
	Max	dB(A)	60	61	61	62
	Sil. 1	dB(A)	55	57	57	58
	Sil. 2	dB(A)	52	54	54	54
Max current absorbed	A	12	14	16	17	
Net weight	Kg	58		77		
Packed unit weight	Kg	65		94		

INDOOR UNIT TECHNICAL DATA		4	6	8	10
Electrical power supply	Vac / Hz	220-240 / 50			
Type of exchanger		Brazed stainless steel plates			
Type of circulating pump / Max. head		Electronic / 9 mca			
Heating system expansion vessel volume	liters	10			
Heating system max. pressure	bar	3			
Heating system plumbing connections		3/4" GAS M			
DHW plumbing connections		1/2" GAS M			
Liquid line cooling connections		3/8" SAE / Ø 9.52			
Gas line cooling connections		5/8" SAE / Ø 15.88			
Hydraulic circuit min. content	liters	15			
DHW storage tank volume	liters	100			
System electric heater	kW	3			
DHW storage tank electric heater	kW	1.2			
DHW expansion vessel volume	liters	5			
DHW max. working pressure	bar	9			
SWL - indoor unit sound power level	dB(A)	39			
Max. absorbed current	A	14			
Net weight	kg	95/103			
Operating weight	Kg	195/218			
Packed unit weight	Kg	98			

*: The factory refrigerant charge allows a maximum cooling line length of 15 meters. If the maximum length of the cooling lines is 30 meters: in this case it is necessary to supplement the charge during installation.

** : SWL = Sound power levels, referred to 1×10^{-12} W with unit operating under conditions: **A7W35** = source : air at 7°C d.b. 6°C w.b. / system : water at 30°C out 35°C **A35W18** = source : air at 35°C d.b. / system : water in 23°C out 18°C **Max** = at maximum conditions in heating / cooling mode **Sil. 1** = if active silent level 1 in heating / cooling mode **Sil. 2** = if active silent level 2 in heating / cooling mode. The total sound power level in dB(A) is measured in accordance with ISO 9614.

***: For combination with outdoor units models 4-6 a reduction from 3/8" SAE to 1/4" SAE for Ø 6.35 liquid line is supplied.

TECHNICAL DATA

HEAT PUMP PERFORMANCE / OPERATING LIMITS

PERFORMANCE DATA			4	6	8	10
A7W35	Nominal heat output	kW	4.2	6.35	8.4	10
	Nominal absorbed power	kW	0.82	1.28	1.63	2.02
	COP	W/W	5.1	4.95	5.15	4.95
	Water flow rate	l/h	722	1092	1445	1720
	Useful static pressure	kPa	82	75	59	43
A7W45	Nominal heat output	kW	4.3	6.3	8.3	10
	Nominal absorbed power	kW	1.13	1.7	2.16	2.67
	COP	W/W	3.8	3.7	3.85	3.75
	Water flow rate	l/h	740	1084	1428	1720
	Useful static pressure	kPa	82	75	60	43
A7W55	Nominal heat output	kW	4.4	6	7.5	9.5
	Nominal absorbed power	kW	1.49	2.03	2.36	3.06
	COP	W/W	2.95	2.95	3.18	3.1
	Water flow rate	l/h	600*	645	806	1021
	Useful static pressure	kPa	84	84	81	77
A35W18	Nominal cooling capacity	kW	4.5	6.5	8.3	9.9
	Nominal absorbed power	kW	0.82	1.35	1.64	2.18
	EER	W/W	5.5	4.8	5.05	4.55
	Water flow rate	l/h	774	1118	1428	1703
	Useful static pressure	kPa	82	74	60	44
A35W7	Nominal cooling capacity	kW	4.7	6.5	7.45	8.2
	Nominal absorbed power	kW	1.36	2.17	2.22	2.52
	EER	W/W	3.45	3	3.35	3.25
	Water flow rate	l/h	808	1118	1281	1410
	Useful static pressure	kPa	81	74	68	61

The values refer to units without possible options or accessories. Data declared according to EN 14511:

EER (Energy Efficiency Ratio) = ratio of cooling capacity to absorbed power

COP (Coefficient Of Performance) = ratio of heat output to absorbed power

A7W35 = source : air at 7°C d.b. 6°C w.b. / system : water at 30°C out 35°C

A7W45 = source : air at 7°C d.b. 6°C w.b. / system : water at 40°C out 45°C

A7W55 = source : air at 7°C d.b. 6°C w.b. / system : water at 47°C out 55°C

A35W18 = source : air at 35°C d.b. / system : water at 23°C out 18°C

A35W7 = source : air at 35°C d.b. / system : water at 12°C out 7°C

* : min. permissible water flow

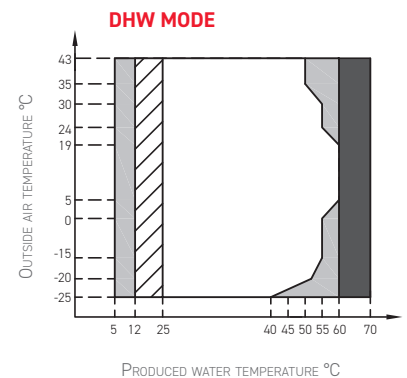
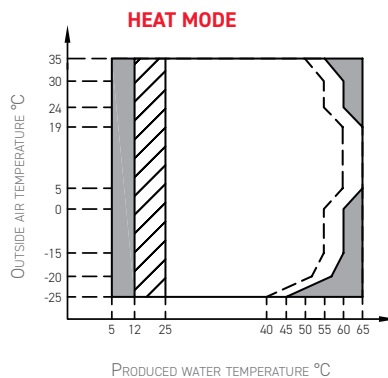
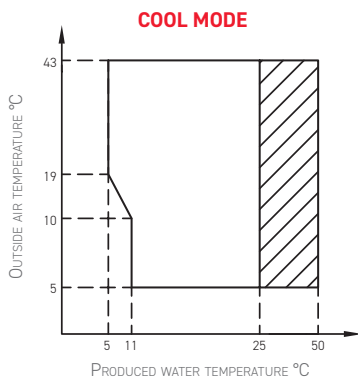

Operating range with heat pump with possible limitation and protection

Operating range with heat pump with possible limitation and protection

Operating range with heat pump with possible limitation and protection

With IBH (system electric heater) installed

With IBH (system electric heater) / TBH (DHW electric heater) installed

Max. inlet water temperature line for heat pump operation

With TBH (DHW electric heater) installed

TECHNICAL DRAWINGS

INDOOR AND OUTDOOR UNITS / HEAD FLOW DIAGRAM

INDOOR UNIT

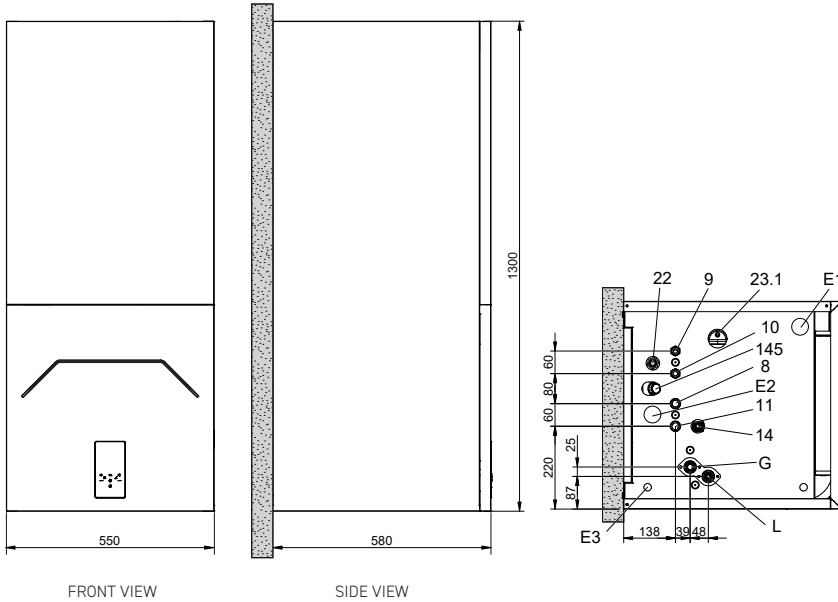

DESCRIPTIONS	SIZE
8 System flow	Ø 3/4 M
9 DHW outlet	Ø 1/2 M
10 DHW inlet	Ø 1/2 M
11 System return	Ø 3/4 M
14 System safety valve / System drain faucet	-
22 DHW safety valve	-
23.1 System expansion vessel filling valve access	-
145 Water pressure gauge	-
E1 Signal cable gland	-
E2 Power cable gland	-
E3 Power cable	-
G Gas line	5/8" SAE / Ø 15.88
L Liquid line	3/8" SAE / Ø 9.52

OUTDOOR UNIT

model 4 - 6

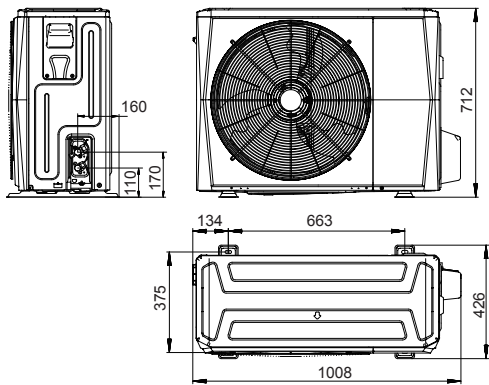

model 8 - 10

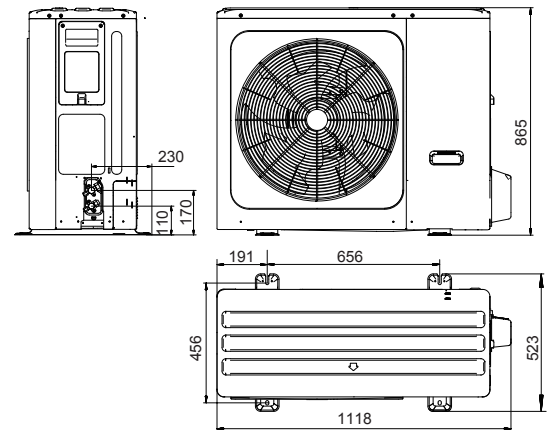

CIRCULATING PUMP HEAD FLOW DIAGRAM - INDOOR UNIT

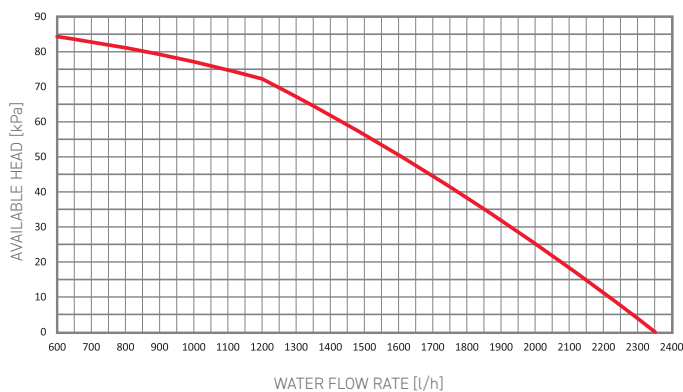

The graph gives the water flow rate limits (min. and max.) and the available static pressure guaranteed by the circulating pump at maximum speed. The speed of the internal circulating pump is managed by the hydronic card to ensure the correct temperature difference of the water as per the table below:

$\Delta t = T_{flow} - T_{return}$	Cooling mode	Heating mode	
	for all setpoints	setpoint < 50°C	setpoint > 50°C
	5	5	8



The illustrations and data provided are indicative. Lamborghini CaloreClima reserves the right to make any changes deemed to be most appropriate for the improvement of the product or of the service offered without being obliged to give prior notice.

The images in this catalogue are under copyright owned by Lamborghini CaloreClima.